

DIMENSION OF EX.GAS OUTLET		
TURBOCHARGER TYPE	TD13	TD15
A	365	383
B	165.5	210
C	275.5	320
D	337	355
E	959	966
F	1059	1066
G	1607	1614
H	564	582
W	1127.8	1145.8

NO.	PARTS NAME	SIZE	REFERENCE
1	WATER PUMP		
2	THERMOSTAT		
3	FRESH WATER INLET	φ9.1	
4	FRESH WATER OUTLET	φ0.5	
5	FRESH WATER INLET (AIR, COOLER)	φ0.5	
6	FRESH WATER OUTLET (AIR, COOLER)	φ0.5	
7	OIL FILTER		
8	OIL BY-PASS FILTER		
9	OIL COOLER		
10	OIL FILLER		
11	OIL LEVEL GAGE		
12	FUEL INJECTION PUMP		
13	FUEL FILTER		
14	GOVERNOR		
15	FUEL PIPE JOINT		
16	FUEL RETURN PIPE	?q?yU+201AR-U+1FDAW	
17	INTER COOLER		
18	TURBOCHARGER		
19	INTAKE AIR SILENCER		
20	EXHAUST GAS OUTLET	φ16.3	
21	MIST GAS OUTLET	φ0.8	
22	FLYWHEEL&HOUSING		
23	STARTER		
24	DYNAMO		
25	FRONT P.T.D. PULLEY		
26	OIL INLET (FOR EMERGENCY)		
27	FILTER ALARM	M5X0.8	
28	BOOST GAGE ADAPTER	?q?yU+201AP-U+1FDAW	
29	THERMOMETER & THERMOSWITCH ADAPTER	?q?yU+201AP-U+1FDAQ	
30	OIL PAN ADAPTER(A)		
31	OIL PAN ADAPTER(B)		
32	OIL PAN ADAPTER(C)	M36X1.5	
33	OIL PRESS.GAGE & PRESS.SWITCH ADAPTER	?q?yU+201AP-U+1FDAW	
34	TACHOMETER ADAPTER		
35	THERMOMETER ADAPTER	Rp3/4	
36	OIL FILTER TANK(FOR GOVERNOR)		
37	FRESH WATER DRAIN COCK		

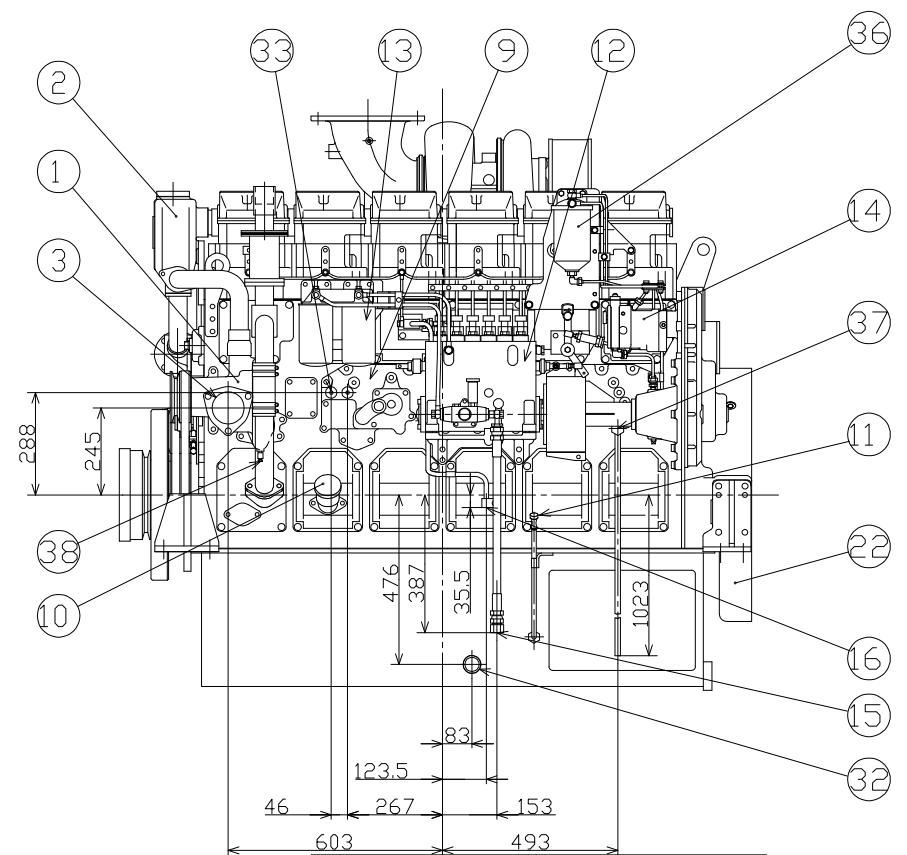
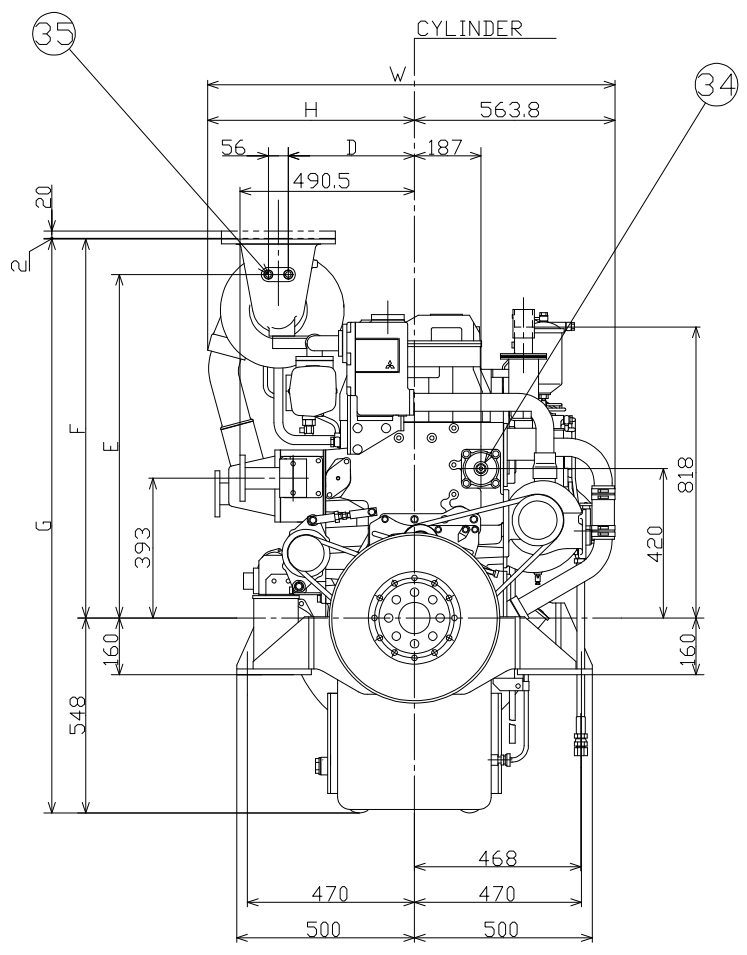
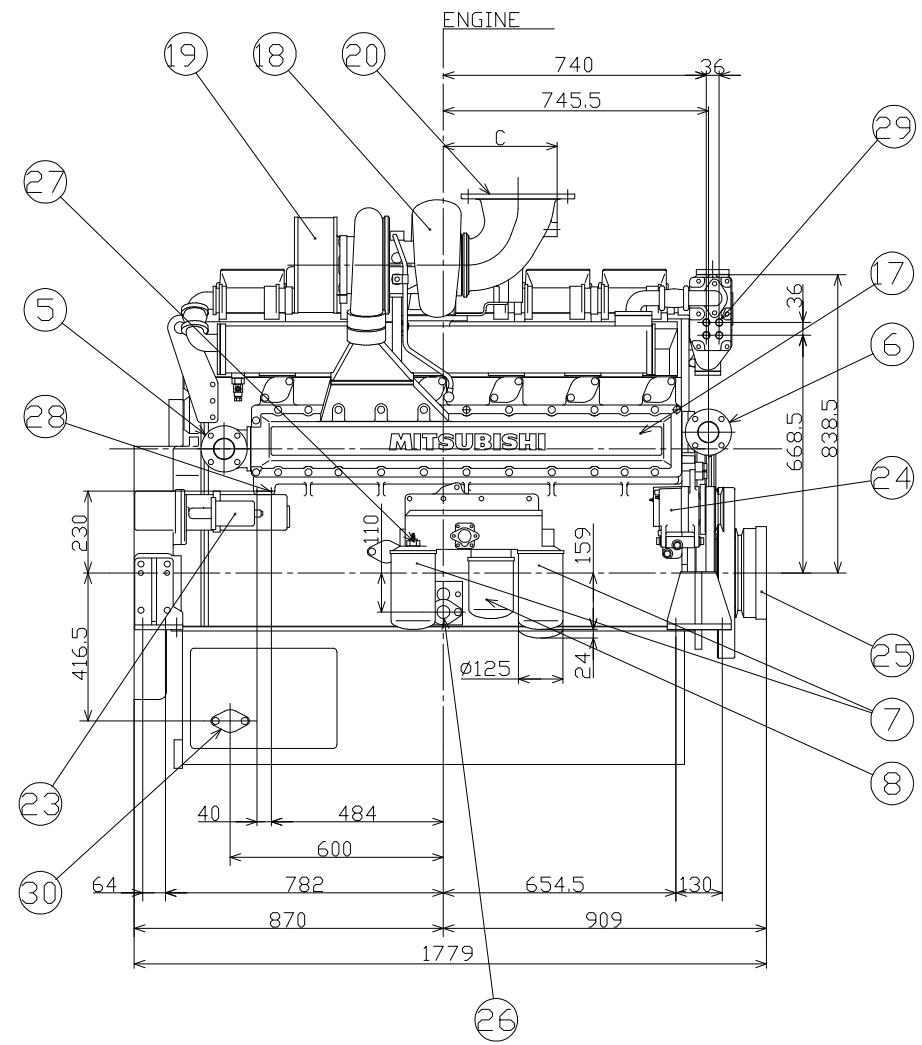

PRELIMINARY

Certified for EU stage VA engine

GENERAL VIEW
S6R-Z3MPTAW

三菱重工業株式会社汎用機・特車事業本部
MITSUBISHI HEAVY INDUSTRIES LTD. GENERAL MACHINERY & SPECIAL VEHICLE HEADQUARTERS

ED-NO 4590-E996 DATE 08.11.06 浅沼 尺 1:10
CHK 福小 製図 谷浅
20.08. 7.30

図面番号 45R96-00203
DRAWING NO.

①新図 ②サイズ ③組立図 ④切欠品 ⑤再加工品 ⑥その他(購入品)

FULL-CAD