

NO.	PARTS NAME	SIZE	REFERENCE
31	OIL INLET (FOR PRIMING)	Rc3/4	45R96-01063
32	OIL PUMP		
33	WATER PUMP		
34	AIR PRESS. GAGE ADAPTER	Rc1/8	45R96-01063
35	THERMOSTAT		
36	TACHOMETER ADAPTER	M23X1.5	45R96-01063
37	MAGNETIC PICKUP ADAPTER	5/8-18UNF	45R96-01063
38	DYNAMO		
39	THERMOMETER UNIT ADAPTER	M18X1.5	45R96-01063
40	THERMOMETER UNIT ADAPTER	Rc1/2	45R96-01063
41	BREATHER OUTLET	φ76.3	
42	FRESH WATER INLET	φ101.6	45R96-01063
43	EXHAUST MANIFOLD		
44	INTAKE AIR SILENCER		
45	TURBOCHARGER		
46	INTER COOLER		
47	FRESH WATER OUTLET	φ60.5	45R96-01063
48	THERMOMETER, ex. ADAPTER	RP3/4	45R96-01063
49	STOP SOLENOID		

NO.	PARTS NAME	SIZE	REFERENCE
1	OIL PAN ADAPTER (A)	M20X1.5	45R96-01063
2	OIL PAN ADAPTER (B)	M16X1.5	45R96-01063
3	OIL PAN ADAPTER (C)	M36X1.5	45R96-01063
4	OIL FILTER		
5	OIL COOLER		
6	OIL BY-PASS FILTER		
7	TORSIONAL VIBRATION DAMPER		
8	FRONT P. T. O. PULLEY		
9	OIL PRESS. GAUGE ADAPTER	Rc1/8	45R96-01063
10	SEA WATER INLET	φ50	45R96-01063
11	SEA WATER OUTLET	φ50	45R96-01063
12	HANGER		
13	OIL PRESS. GAUGE ADAPTER (A)	Rc1/8	45R96-01063
14	OIL PRESS. GAUGE ADAPTER (B)	Rc1/8	45R96-01063
15	FUEL FILTER		
16	FUEL INJECTION PUMP		
17	EXHAUST GAS OUTLET	φ355.6	
18	GOVERNOR		37896-63001
19	MAGNETIC PICKUP ADAPTER	5/8-18UNF	45R96-01063
20	FLYWHEEL HOUSING		37896-21002
21	FLYWHEEL		37896-21002
22	WATER DRAIN COCK		
23	GOVERNOR OIL FILTER		
24	STARTER		
25	OIL LEVEL GAUGE		
26	FUEL LEAK OFF PIPE ADAPTER	Rc3/4	45R96-01063
27	OIL FILLER		
28	FUEL INLET PIPE ADAPTER	Rc3/4	45R96-01063
29	OIL RELIEF VALVE		
30	OIL PAN ADAPTER (D)		45R96-01063

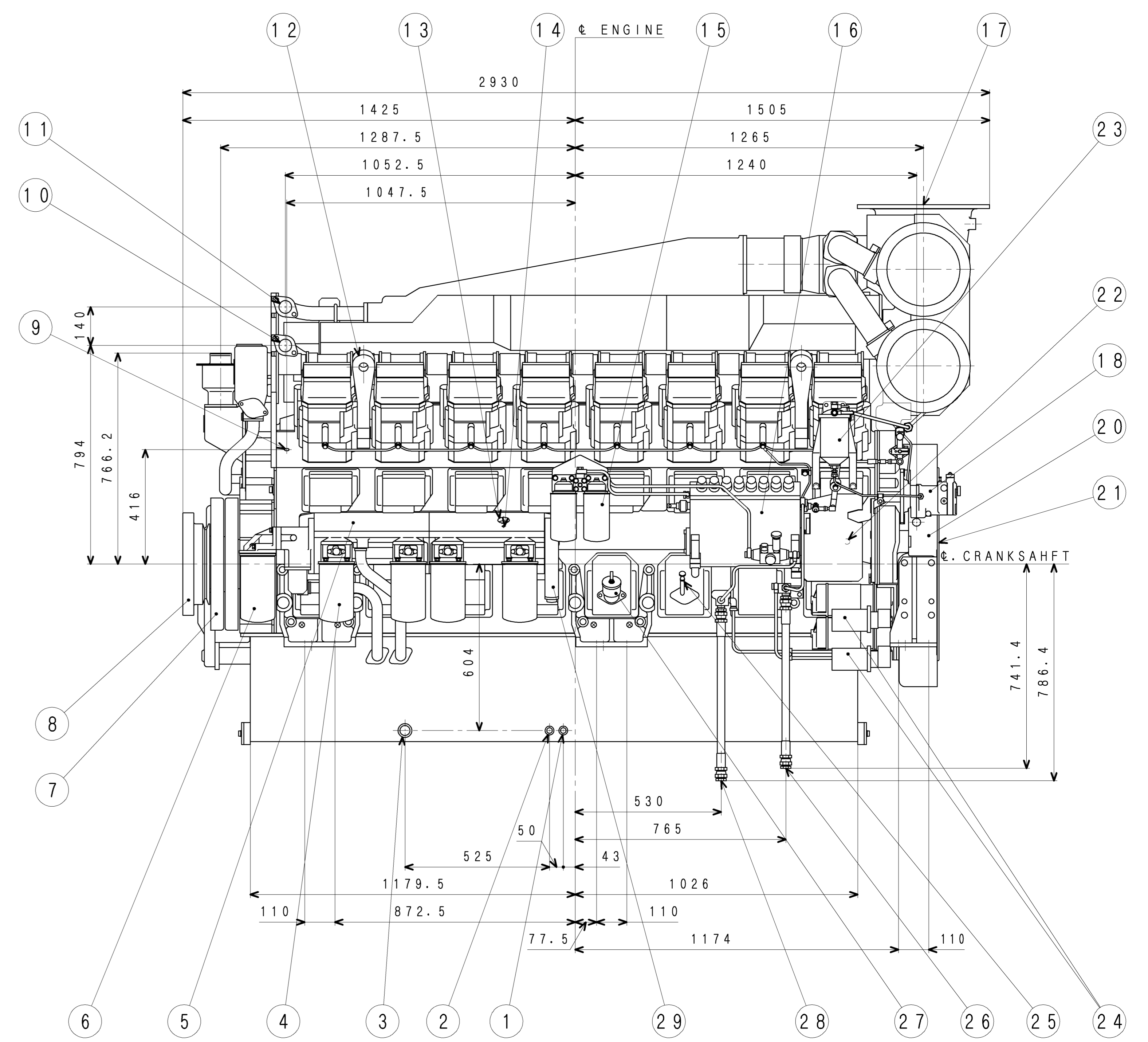
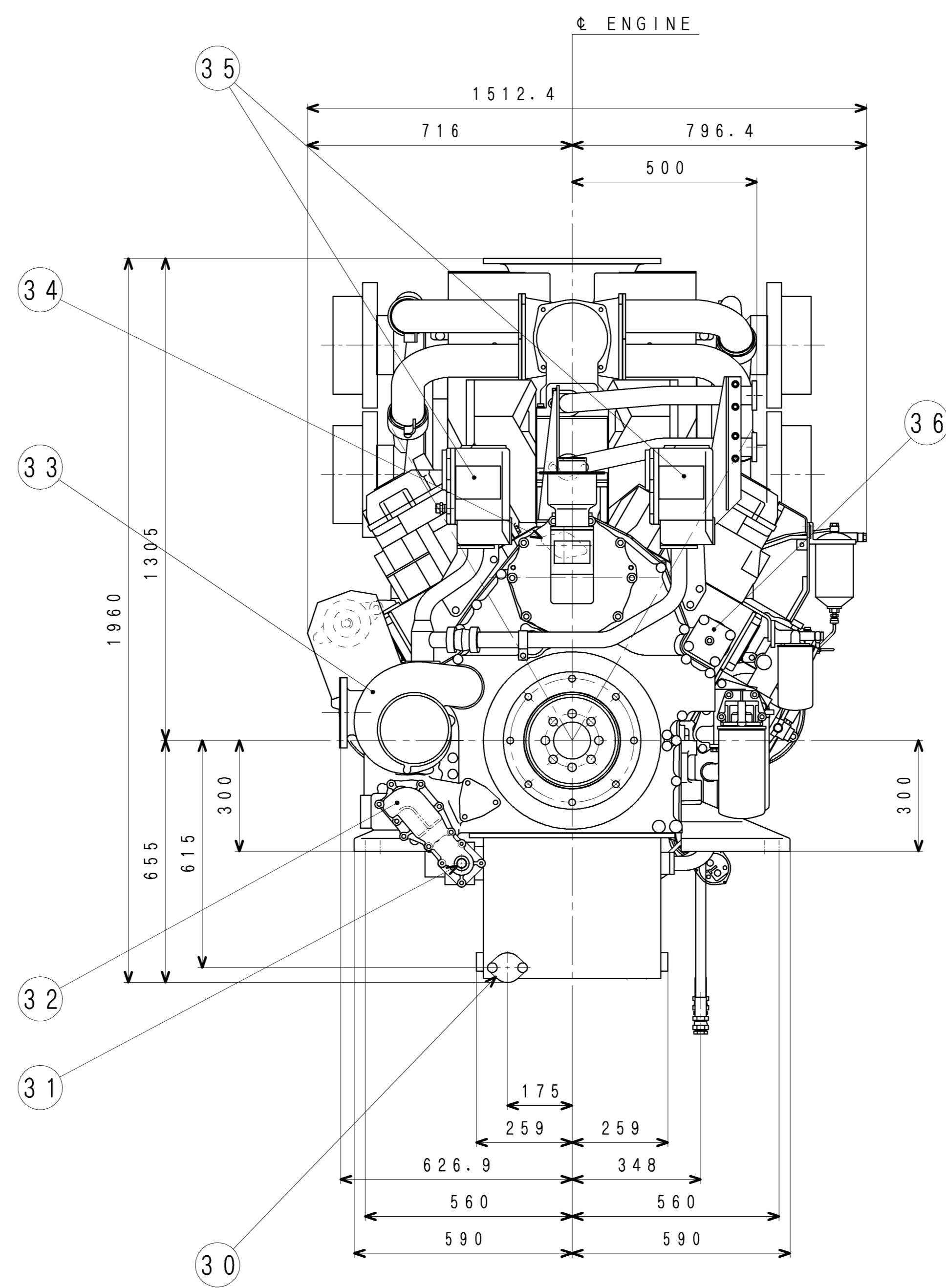
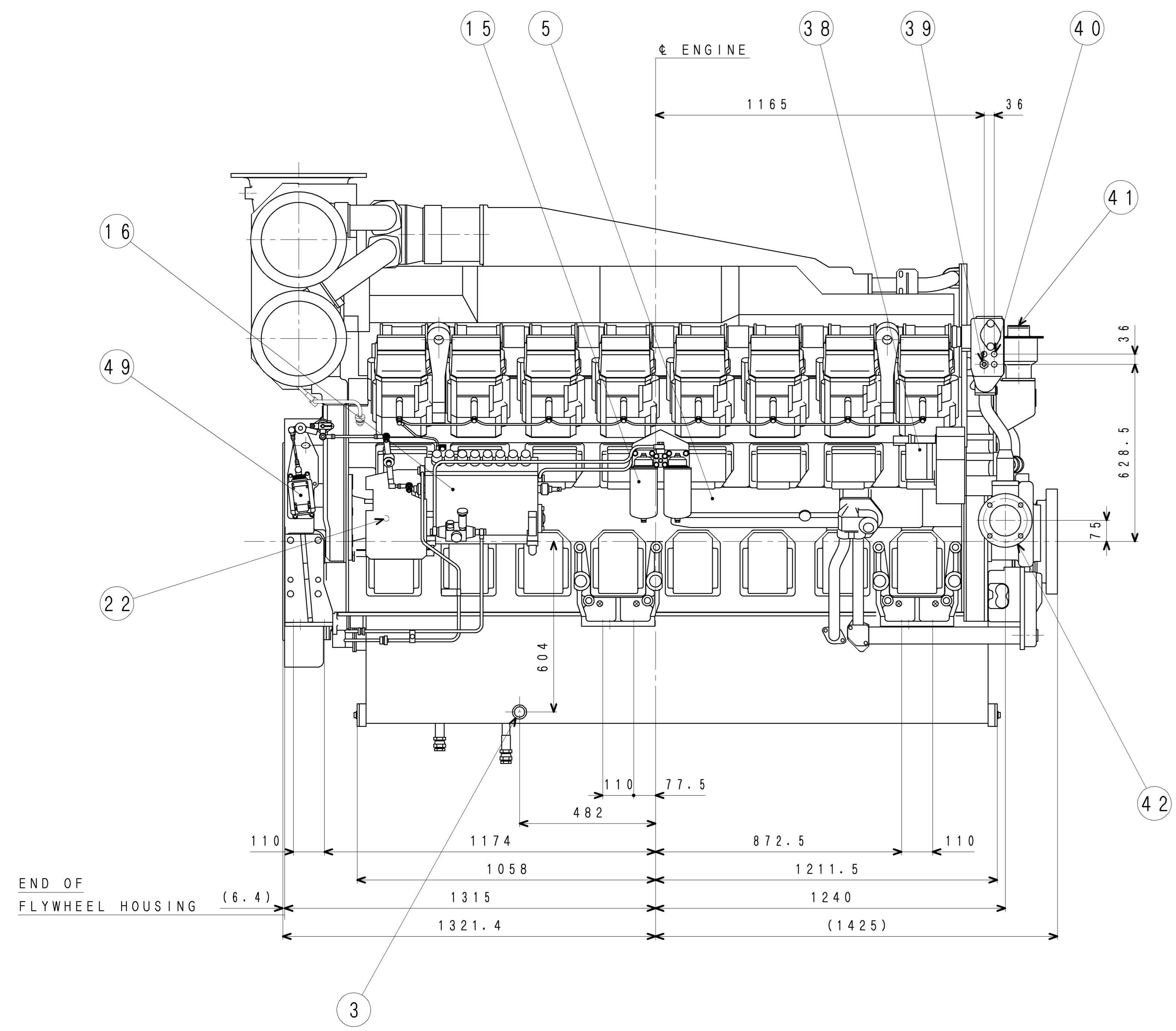

37.5° ANGLE PROJECTION  
 尺度 SCALE  
 三菱重工業株式会社 汎用機・特車事業本部  
 MITSUBISHI HEAVY INDUSTRIES, LTD. GENERAL MACHINERY & SPECIAL VEHICLE DEPARTMENTS.  
 図面番号 45R96-00353  
 2007. 7. 31

CHG	REV	DATE	CHK	ENK
松平	橋本	橋本	橋本	橋本

出図  
 汎特  
 2007  
 7.31  
 FULL-CAD